



HEALTHCARE CARTS & POINT-OF-CARE PRODUCTS



CAPSAHEALTHCARE

Distributed By

SYSTEMZ

Medication Carts
Computing Workstations
Wall Arms

A white medical device, likely a patient scale, is shown in the foreground. It features a large touchscreen display with a blue border and a red 'CAPSA' logo. The screen displays a user interface with various icons and text. Below the screen is a white keyboard and a mouse. The device has a handle on the right side. In the background, a whiteboard is partially visible.

Elevating performance,

every day.

Through inventive product design and commitment to customer support, Capsa Healthcare has been a market leader for over 50 years.



Capsa Solutions and Rubbermaid **Healthcare** have been fully integrated to form **Capsa Healthcare**.

Collectively, our passion as a single organization is born out of the same commitment and purpose that our customers have to providing superior patient care. We understand the delivery of healthcare cannot wait which is why we continually invest in product development, technology innovation, service, and support to make sure we are the logical choice for products that elevate the performance of healthcare delivery at the point-of-care.

Capsa Healthcare provides an extensive portfolio of mobile computer carts, point-of-care wall mount products, and creative service programs designed to optimize your health I.T. program. With improved cart uptime and simple serviceability, Capsa's mobility solutions improve user experience and support better clinical workflow.

Welcome to **Capsa Healthcare**.

Inquire about special
Refresh '17 Tailored Cart Fleet
Replacement Program.





M38e

Computing Carts

The NEW M38e from Capsa Healthcare is an evolution of the most proven point-of-care computing cart in healthcare. With updated features that provide superior ergonomics, enhanced ease-of-use, and expanded storage flexibility, the M38e maximizes clinical efficiency and elevates the performance of your health IT program.

- 15% smaller profile glides through tight care settings
- 10% larger work area with additional 100 square inch expandable surface feature
- 25% increase in battery runtime for improved uptime performance
- Up to 24% larger CPU storage area affords organized tech organization



Comfortable two-position handles simplify mobility



Intuitive locking and security system



Integrated storage pods and protective document cover



M38e



M38e

Features & Models



Choose from an array of workflow and accessories options



Choose from an array of flexible storage options



Efficient Li-ion power in cart base or swappable pack system



M38e
Document Model



M38e
RX Model

General Specifications:

- Top Work Surface Size: 19.6" w x 10.5" d
- Casters: 5" directional casters
- Choose from manual or electronic lift
- Adjustable monitor mount and keyboard tray
- Enhanced power base with improved ventilating system for safety
- Intuitive locking and security system

Optional Accessories:

- LCD access pack
- Monitor height adjustment w/swivel
- Wire basket
- Scanner mount options
- Large printer shelf
- Trash bin
- Dual monitor mounts

Power System	Non-Powered	AC Powered Lithium
Target Run-Time (typical configuration):	Laptop Battery Only	7-10 Hours/Charge
Charge Time from Empty:	Laptop charge time only	2.5 Hours
Battery Life Cycles:	N/A	2500+
Recommended Technology:	Laptop (up to 17" screen)	Laptop (folded), thin client, or All-In-One PC



CareLink™

Mobile Nurse Station

CareLink Nurse Workstations elevate mobile computing to the next level, with improved communications, N-Stride steer assist, and an intelligent platform for proactive cart fleet management. CareLink provides ergonomic features and workflow solutions that will simplify the rigorous day-to-day tasks associated with providing patient care.

- Fully configurable storage and organization
- Two-position front handle and rear handle for easy maneuvering
- Keyboard, work surface, and lights for working in darkened rooms
- Smooth non-porous surfaces for easy cleaning and durability
- T-track provides universal mounting point for accessories
- Use a laptop or your choice of computing hardware



Saves Time

CareLink's 7" glass touchscreen enables improved communications and simplified use



Easier to Move

With N-Stride™ steer assist, CareLink is virtually effortless to maneuver and control



Intelligent Platform

Remote fleet management with no software to install or maintain



CareLink
Nurse Workstation



CareLink™

Features & Models



On-board Calculator

enables bedside calculations



Work Surface

expands for additional workspace

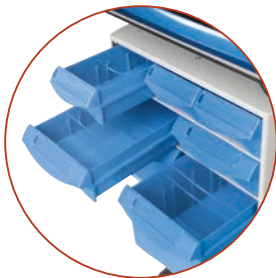

Multiple Drawer Options

configurations address specific needs



CareLink XP

Shown with Laptop



CareLink RX

Shown with LCD

General Specifications:

- Base Size/Footprint: 17" x 19"
- Cart Weight (lbs): 106 plus
- Height Adjustment: Adjustable Tension Spring
- Height Adjustment Mechanism Range: 16"
- Top Work Surface Size: 21"w x 10"d
- Casters: 5" casters; 2 locking

Optional Accessories:

- LCD access pack
- Rotating monitor bracket
- Wire basket
- Scanner bracket Kit
- Large printer shelf
- Trash bin

Power System	Non-Powered	AC Powered Lithium
Target Run-Time (typical configuration):	Laptop Battery Only	7-10 Hours/Charge
Charge Time from Empty:	Laptop charge time only	2.5 Hours
Battery Life Cycles:	N/A	2500+
Recommended Technology:	Laptop (up to 17" screen)	Laptop (folded), thin client, or All-In-One PC



CareLink™

Features

Saves Time

Reduce time wasting activities and increase time spent with patients



Communication Tools

Using on-board messaging software, sending service requests and receiving notifications is easier than ever

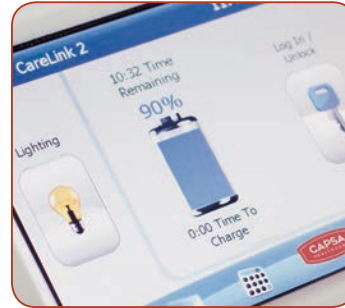

Battery Life Icon

Easy-to-read battery status icon indicates the exact amount of uptime remaining



Electronic Lift

Save personalized preferences, such as seated and standing heights, through a fleet-wide memory system



External USB Ports

Easy access to ports and power without removing the work surface

Easier to Move

Improved maneuverability and ergonomics assist with workflow and decrease patient disruptions



N-Stride Steering Control™

By locking a front caster, users can easily navigate halls and turn corners without unnecessary strain



Dual-Position Handles and 5" Casters

Ergonomically designed handles provide additional user comfort, while larger casters help cross thresholds and maneuver over carpet



Additional Lighting Options

Three lighting options assist with navigating and working in darkened areas without disrupting patients



Height-Adjustable Rotating Monitor

Easy-to-move adjustable monitor helps ensure proper ergonomics to both prevent injury and promote sharing of information with patients



CareLink™

Features

Intelligent Platform

Helps clinicians focus on patient care with an intuitive, flexible platform designed to avoid obsolescence

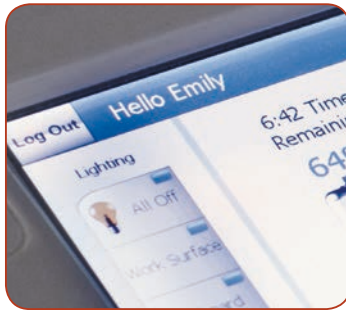

Individual Preference Settings

Personal preference settings are saved and transferred to all carts



Proactive Fleet Management

Independent fleet management software allows for remote configuration and upgrades, asset monitoring and utilization, and cart locators



Flexible to Meet Changing Needs

Future-proof design provides a universal power system and ability to easily upgrade to medication administration without purchasing a new cart



Software-Based Platform

Out-of-the-box software requires no installation or maintenance on hospital servers

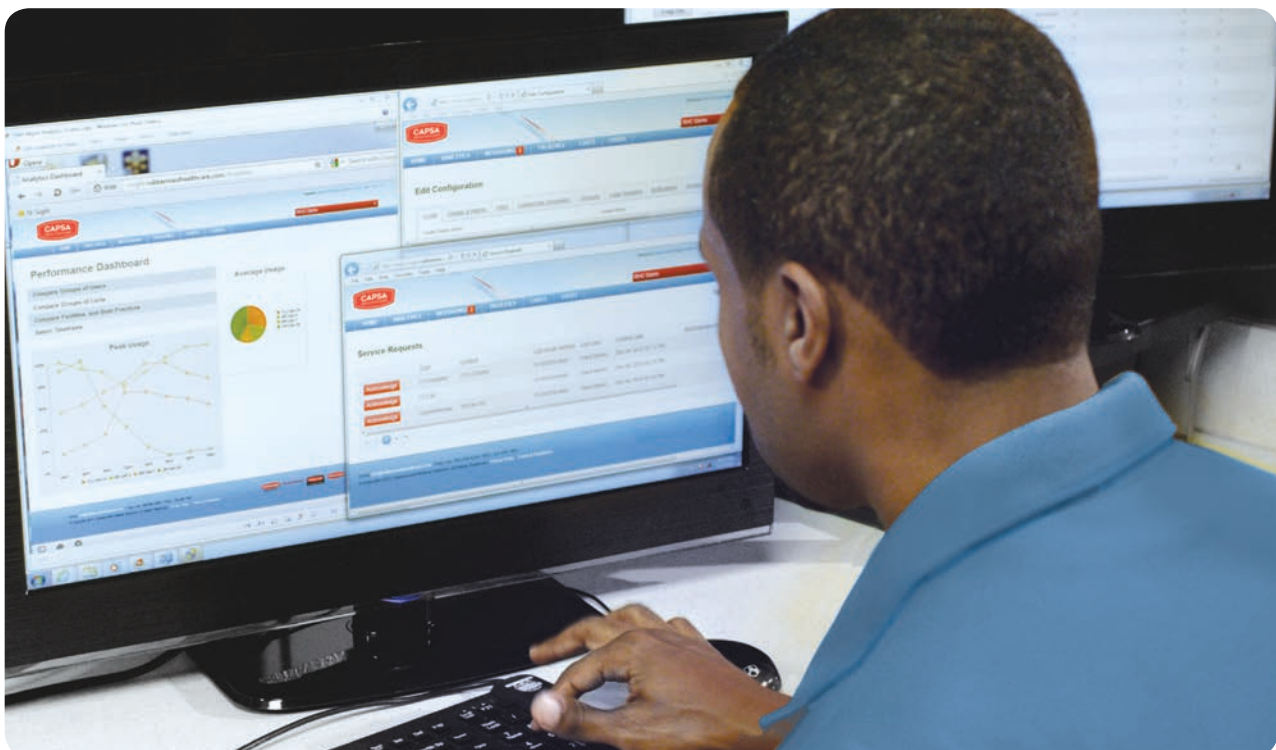



Specialty Carts

CareLink™ Fetal Monitoring Cart

The NEW CareLink Fetal Monitoring cart provides both fetal monitoring and a mobile workstation in a single solution. Your choice of medical monitoring system promotes workflow efficiency in labor and delivery departments



Features

- Dual-swivel monitor mount supports up to 22" monitors
- Stable open shelf supports and secures a variety of Fetal Monitoring systems On-Board communication tools for receiving messages and sending service requests
- N-Sight fleet management for remote asset management
- N-Stride steering control for effortless maneuverability and control
- Expansive work surface
- Height adjustable with electronic lift

CareLink™ High Capacity Medication Cart

With its compact footprint and flexible drawer system, the CareLink High Capacity Double RX Medication Cart maximizes nurse efficiency, mobility and patient safety.



Features

- 5 Drawer sizes that can be mixed and matched to individual unit and nurse preferences
- Integrated keyboard and drawer light feature auto shut-off for nighttime use
- Electronic keyless entry system
- Locking side bind provides additional locked storage that is removable for easy supply retrieval
- Communication tools: receive messages and send service requests
- N-Sight fleet management for remote asset management

Telehealth Carts & Wall Mounts

From basic platforms to those with enhanced functionality, our Telehealth solutions are simple, versatile and clinical. Choose from Telepresence cart solutions that will accommodate video conferencing technologies, to Telemedicine platforms for integrating medical peripheral cameras and scopes. Wall mount solutions offer flexible configurations for tighter space requirements. The CLINiC Telehealth consultation device provides an easy-to-use, intuitive interface.



Features

- Telemedicine platforms offer I/O panel plug-n-play to easily integrate medical peripheral cameras and scopes with customer supplied PC or Codec
- Telepresence carts enable video communication to enhance workflow, with real-time consultations
- Wall mount solutions provide another virtual care platform with a small, lightweight footprint, requiring minimal wall space.
- The CLINiC clinical care device offers flexible configurations that connect doctors and clinicians to patients.

Accessories



*LCD Access Pack
for med cups,
tape and
alcohol wipes*



*Mounting
Bracket for
Caviwipes
Bracket*



*Large
Printer Shelf
15" w x 9" d*



*Rotating 5" Height
Adjustment
Monitor Bracket*



*3-Sided
Mounting
Bracket*



Wire Basket



*Rotating Monitor
Bracket*



*Mounting Plate
for Sharps
Bracket
and Accessory
Bins*



Trash Bin



*Locking Side
Bin with
removable bin*



*Barcode
Scanner
Charging
Station Shelf*



*IV Pole 25" H x .75"
Diameter*

Check with your Capsa Healthcare regional sales manager about these and more accessories specific to your chosen point-of-care solution.

Swappable Batteries

Swappable battery power systems use removable batteries that can be charged in a location, separate from the cart.



*Elora 240
swappable
batteries allow
cart to run 24/7
with no downtime*



*Battery mounting
bracket provides easy
access to remove and
replace swappable
batteries*



*Smart charging cabinet shows which
battery is charged and ready for next
use, ensuring all batteries are used
equally for maximum battery life*



Additional Information

Ask Capsa Healthcare for more information about our benchmark solutions for point-of-care mobile computing, wall mount products, or advanced medication management systems.



Web Site

Visit the Capsa website to learn more about our comprehensive line of products that support your healthcare I.T. program. The website provides in-depth information about product features, options and specifications that will give you the insight you need to find the perfect solution for your facility.

www.CapsaHealthcare.com



Email

To request more information about Capsa products or to learn more about regional representation or distribution partners in your area, simply send us an email:

Info@CapsaHealthcare.com



Phone

If you have specific questions and wish to speak with someone directly, contact Capsa Healthcare and ask for Customer Service.

[800.437.6633](tel:800.437.6633)



Certified ISO
27001:2013



Certified ISO
9001:2008

Storage Selection

Your Storage Selection

Add additional storage options from the right. Check the box to select, then confirm to proceed to the next bay

- select --
- select --



Select Storage

No Thanks ▶

Your Storage Selection

Add additional storage options from the right. Check the box to select, then confirm to proceed to the next bay

- select --
- 4 Drawer Vertical Expansion Pack



Select Storage

Click here to confirm your selections



CareLink™ platform offers a variety of high capacity options to accommodate your unique medication administration workflows. Choose from a variety of drawer configurations and sizes that best suit your needs.

[View Catalog](#)



Full Drawers



Accessories

Customizable Drawer Options

M38 RX Mobile Medication Models



Rx 4-level configuration

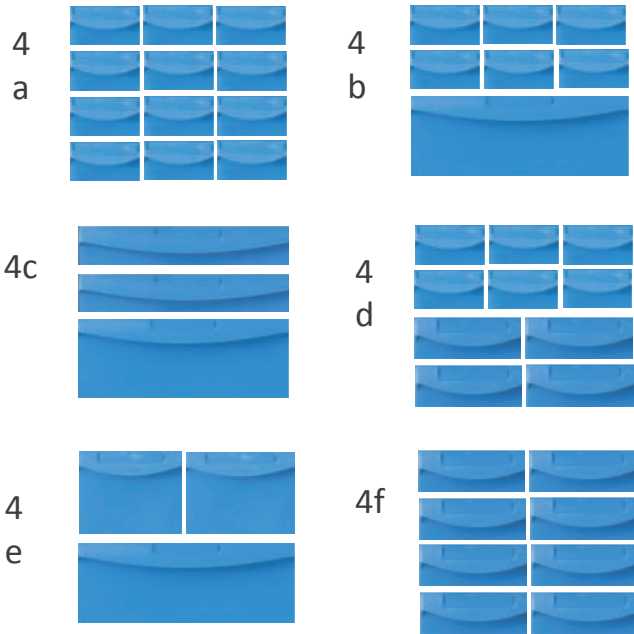

Xp 2-level configuration



SIDE EXPANSION KIT

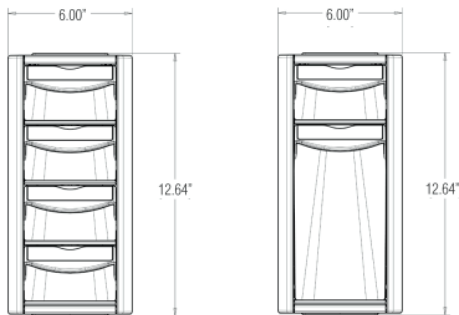

1.1- 98 W x 272 D x 50 H



1.2- 156 W x 272 D x 50 H



1.3- 325 W x 272 D x 50 H



2.2- 156 W x 272 D x 120 H



2.3- 325 W x 272 D x 120 H



1.3- 98 W x 272 D x 200 H
(vertical expansion kit only)





Accessories

Side Expansion Kit

Your Storage Selection

Add additional storage options from the right. Check the box to select, then confirm to proceed to the next bay

-- select --

4 Drawer Vertical Expansion Pack



Select Storage

Click here to confirm your selections

Sections: 1 2



4 Drawer Vertical Expansion Pack



2 Drawer Vertical Expansion Pack



Locking Side Bin

Product Description

The Vertical Expansion Pack can be added to the side of an M38 RX in order to provide additional storage for necessary items at the point of care.

Features and Benefits

- Storage of items on cart allows for a more efficient workflow.
- Drawers maintain a locking mechanism in order to ensure the security of items.
- Option of two or four drawers cater to user's storage preferences.

Specifications

Accepted on all M38 RX Carts.

Dimensions: 12.64" h x 6.00" w x 15.65" d

Note: The 4 Drawer Expansion Pack Module has 4 small drawers, whereas the 2 Drawer Expansion Pack has 1 small drawer and 1 three-deep tall drawer.



Vertical Expansion Pack 2 Drawer Module

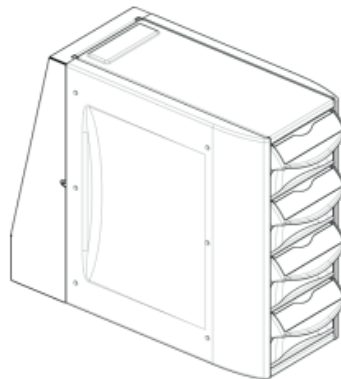
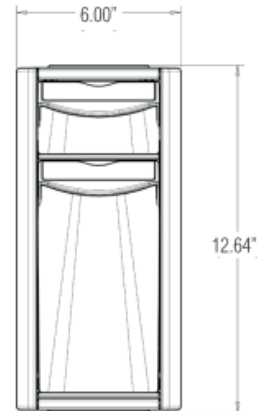

Vertical Expansion Pack 4 Drawer Module

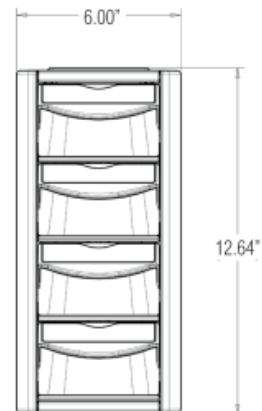

Accessories

Customizable Drawer Options



+



Liquid Storage

+

Customizable Drawer Options

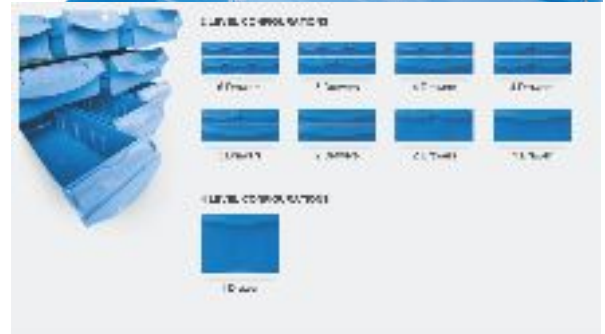

SYSTEMZ
www.systemz.sg



SYSTEMZ
www.systemz.sg



SYSTEMZ
www.systemz.sg

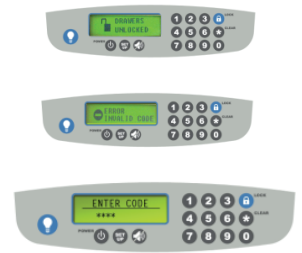



Possible Configuration

Deployment in Singapore by Systmz





Possible Configuration

Deployment in Singapore by Systmz





Rubbermaid Healthcare Recognized by KLAS Research for Impact on Nursing Efficiency and Patient Safety

Nurses rate Rubbermaid Healthcare highest in efficiency compared to five other vendors of medication carts

About KLAS

KLAS is a research firm on a global mission to improve healthcare delivery by enabling providers to be heard and counted. Working with thousands of healthcare executives and clinicians, KLAS gathers data on software, services, medical equipment and infrastructure systems to deliver timely reports, trends and statistical overviews. The research directly represents the provider voice and acts as a catalyst for improving supplier performance. KLAS was founded in 1996, and their staff and advisory board average 25 years of healthcare information technology experience. Follow KLAS on Twitter at www.twitter.com/KLASresearch.

CART'S IMPACT ON EFFICIENCY AND PATIENT SAFETY



Elevating performance,

every day.



CAPSAHEALTHCARE

www.CapsaHealthcare.com | 800.437.6633

4253 NE 189th Avenue
Portland, OR 97230